

We are planning to provide our customers with tips and helpful suggestions regarding the installation and use of our Finetune-Pegs. If necessary we will also post them on our website and add them to our instruction leaflet every now and then.

→ **Mounting of the WITTNER Finetune-Pegs:**

When mounting the WITTNER Finetune-Pegs please take into account that compared with wooden pegs they slide a bit further into the peg hole as an experienced instrument maker is used to.

The WITTNER Finetune-Peg has to be **PRESSED** into the peghole a bit stronger than any wooden peg since you only push it into the peghole rather than screw (turn) it in like any wooden pegs.

And again: Don't PULL but PUSH the WITTNER Finetune-Peg from behind if you've to remove the peg.

Preparing the peghole:

Using a reamer you should very carefully approach the correct diameter so the Finetune-Peg is not yet at its final position (+ 0,5 mm). Now make a mark on your reamer and equally carefully ream the holes for the remaining pegs.

The ideal position is when the upper shaft is flush with the wood line or goes in up to 1 mm into the peghole.

Make sure that the Finetune-Peg sits really firmly in the peghole (*see drawing No. 1*).

The end shaft of the Finetune-Peg can be shortened by 8 mm and should have a minimum length of 15 mm (*see drawing No. 2*)

The peg-shaft can be worked on with sandpaper, can be cut and treated like any other regular wooden peg – however cannot be shaped with a peg shaper due to its construction.

→ **Converting instruments with the WITTNER Finetune-Pegs:**

Before mounting the Finetune-Pegs the pegholes have to be cleaned from any residue of peg lubricant using a matching reamer. Otherwise a sufficient grip to keep the pegs in place can not be guaranteed.

General remark:

Once you tune the instrument and you turn the Finetune-Peg you can feel some increments, but still can precisely tune the instrument. Just solely focus on the tuning process. It does *not* make any difference how the gears are positioned. Even though the gear tooth engagement is noticeable the peg will lock in any position. This means the tuning operation can be conducted very precisely. The movement is uniform and the pegs are infinitely adjustable. Just focus on the tuning and not on the gears.

Encl.

Drawings No. 1 + 2

Instructions "How to fix the string"

WITTNER GmbH & Co. KG

Postfach 1464

88308 Isny / Germany

Tel. 0 75 62 – 7 04 – 0

Fax: 0 75 62 – 7 04 – 14 Email: wittner@wittner-gmbh.de

Exp.Dept.0 75 62 – 7 04 – 28 Website: www.wittner-gmbh.de

Zeichung Nr. 1 + Nr. 2
Drawing No. 1 + No. 2

Instructions regarding the
installation of the
SAZ-Finetune-Peg

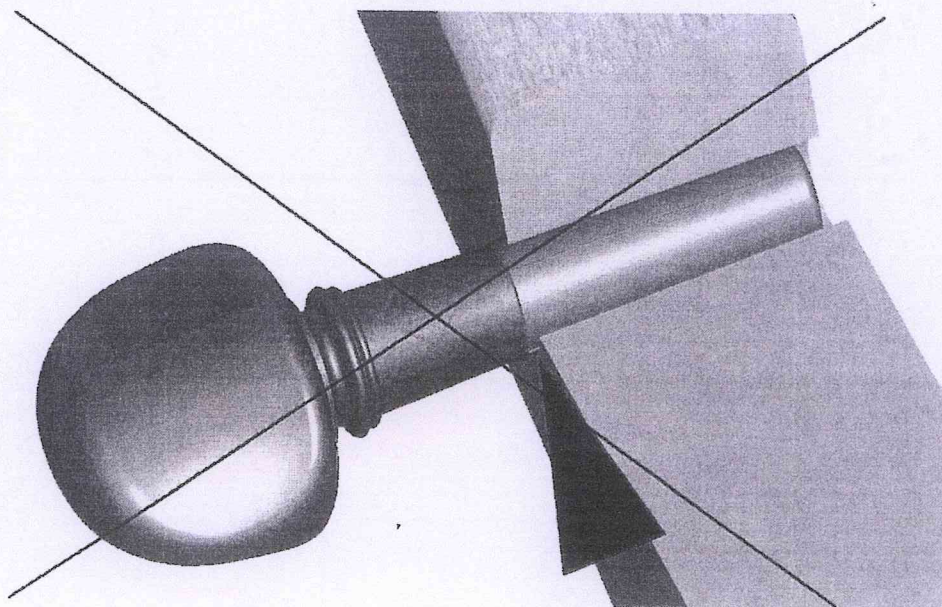
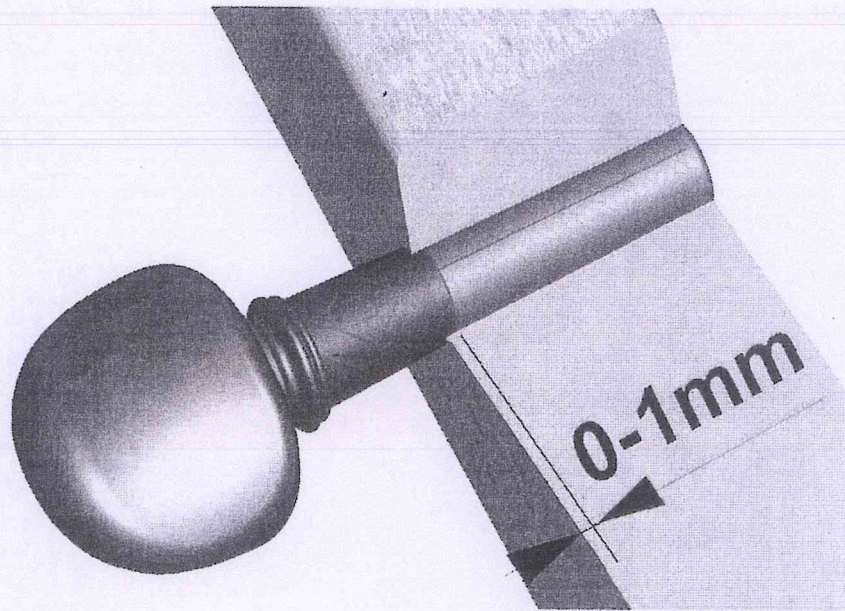
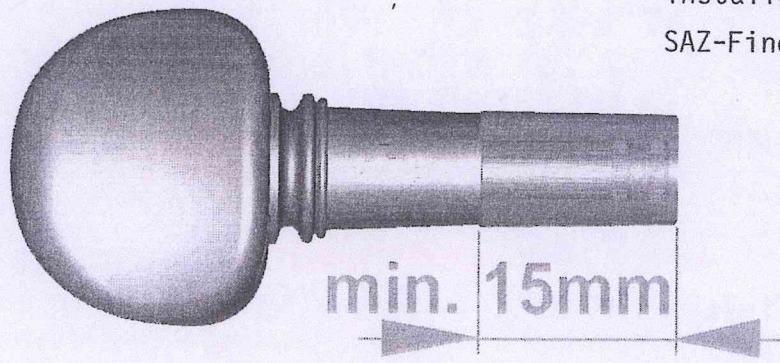

WITTNER GmbH & Co. KG
P.O. Box. 1464, D-88300 Isny
Buehlbergstr. 5-6, D-88316 Isny

1.)

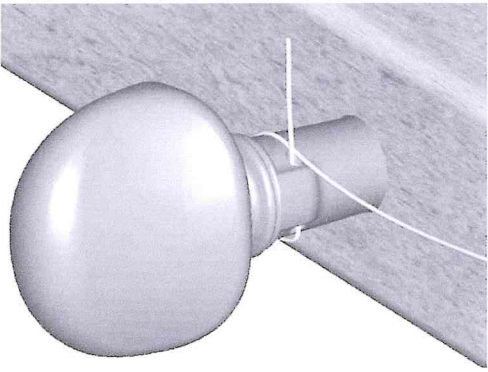

2.)

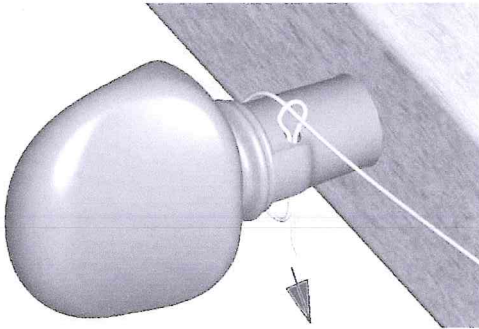

3.)

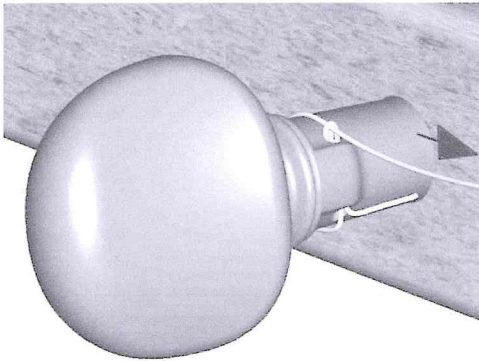

4.)



WITTNER GmbH & Co. KG

P.O. Box. 1464, D-88308 Isny
Buehlbergstr. 5-6, D-88316 Isny